

Level Measurement

Visual Level Indicators VLI
Tank Level Instruments TLI Industry
Tank Level Instruments TLI Marine



Instruction Manual

Magnetic switch

Accessories for WEKA Visual Level Indicator (VLI)

Magnetic switches:

37557

37589

31130-NN, -NW, -NA, -NK, -NP, -NT, -NB, -NI, -ND, -NM, -NS

31160-NN, -NW, -NA, -NK, -NP, -NT, -NB, -NI, -ND, -NM, -NS

31130-NA-NAM

31130-NW-NAM

Date: 31.08.2021

Version: E 2.0

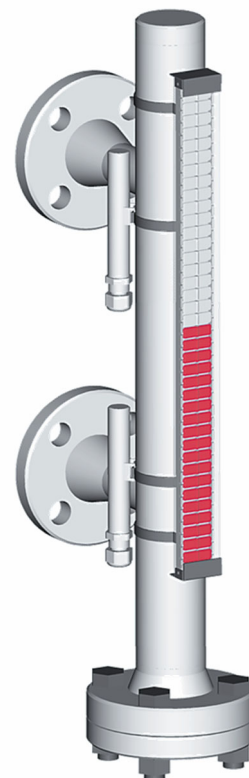

Notes



Order:

Date:

Contents

1.	Symbols and signs used in the instruction manual	3
2.	Safety notes and warnings	3
3.	Intended use	4
4.	Overview of magnetic switches	5
5.	Type codes	6
6.	Functional description	7
7.	Switch function	8
8.	Scope of delivery	9
9.	Unpacking	9
10.	Disposing of packaging materials	9
11.	Assembly	10
12.	Commissioning	12
13.	Maintenance	12
14.	Transport and storage conditions	13
15.	Technical data	13
16.	Dismantling / Disposal	14
17.	Troubleshooting	15
18.	Labelling	16
19.	Customer service	16
20.	EU- Baumusterprüfbescheinigungen	17
21.	IECEX- Certificate of Conformity	24
22.	Declaration of Conformity	31

1. Symbols and signs used in the instruction manual

	<p>Warning Indicates potential damage to the device and / or an injury of the operator or user in case of failure to observe the instructions.</p>
	<p>Caution Indicates potential damage to the device in case of failure to observe the instructions.</p>
	<p>Safety note For equipment with normal conditions of use in explosion-prone environments according to EU-Directive 2014/34/EU (ATEX) or IECEx scheme. These notes apply in addition to all other notes.</p>

2. Safety notes and warnings

The manufacturer is not liable for damages which are caused as a result of failure to observe safety notes and warnings.



- Burn hazard! Work on hot magnetic level indicators can lead to bodily injuries and burns. The surfaces of the float chambers and the process connections can become hot. Let the tank cool down to ambient temperature prior to carrying out any work on the magnetic level indicator. Wear appropriate PPE (gloves, face protection, possibly respiratory protection equipment). Keep sufficient distance during operation.
- The magnetic level indicator and thus also the magnetic switch can unnoticeably become inoperative by a blocking of the float. Should you be unsure about the liquid level indicated, another method should be used to check the magnetic level indicator.
- Should you suspect a defective function, or should you find such defective function, it must be remedied.



- Only use the magnetic level indicator and the magnetic switch, once you have read and understood the complete instruction manual.
- The present instruction manual must also be accessible for later users.
- Keep magnetic and magnetisable parts (magnets, construction steel, steel wire or clamps etc.) away from the magnetic level indicator or accessories such as the magnetic switch. This also applies to strong electromagnetic fields (transformers, welding equipment etc.), as both can interfere with the magnetic force of the magnets contained in the magnetic level indicator or the magnetic switch and can lead to malfunctions or failures of the indicator or the accessory parts (switch, data measuring converter) attached.
- Replace damaged or faulty components with original spare parts.
- Solvents can blunt the plastic components used or can cause cracks. Clean the devices with soap and water or a plastic cleaner.



- Falling parts (boltings, floats etc.) can create impact sparks and cause explosions in an explosion-prone atmosphere. Make sure that an explosion-prone atmosphere does not exist, and no parts fall down when working on the magnetic level indicator.



- When working on the magnetic level indicator, use only equipment and tools which were approved for the explosion-prone area according to the European directive.



- Polycarbonate indicator rails can be electrostatically charged, e.g. during cleaning. When discharging, sparks can cause explosions in an explosion-prone atmosphere. Please clean the parts only with anti-static cleaning agents and auxiliary tools.

3. Intended use



- The magnetic switches may only be used in connection with original Weka magnetic level indicators and their individual parts, e.g. floats.
- The magnetic switches may only be used for the intended use indicated on the type plate. The data recorded on the type plate and the data sheet must correspond to the maximum operation parameters occurring within the plant.
- Intended use, rebuilding measures and alterations of the magnetic switch not provided by the manufacturer are carried out at one's own risk and are potentially dangerous (exclusion of warranty).
- The magnetic switches may only be installed, commissioned and maintained by trained specialist staff.
- The manufacturer is not liable for damages which are caused by improper use or incorrect operation.
- The magnetic switches are classified according EN 61140 to protection level II and will be high voltage tested for 100% each.



- The magnetic switches may only be used for the intended use indicated on the type plate and the labelling according to Directive 2014/34/EU and/or IECEx.



- The magnetic switches may only be installed, commissioned and maintained by trained specialist staff with knowledge on EX protection.



- The magnetic switches may only be repaired and modified by the manufacturer (where required in consultation with the mentioned body).

4. Overview of magnetic switches

<p>Mini with cable gland</p>	<p>Mini with plug connector</p>	<p>Standard with cable gland</p>	<p>Ex i with cable gland</p>
<p>Standard with plug connector M12-A</p>	<p>Standard with junction box</p>	<p>Ex d with cable gland</p>	

5. Type codes

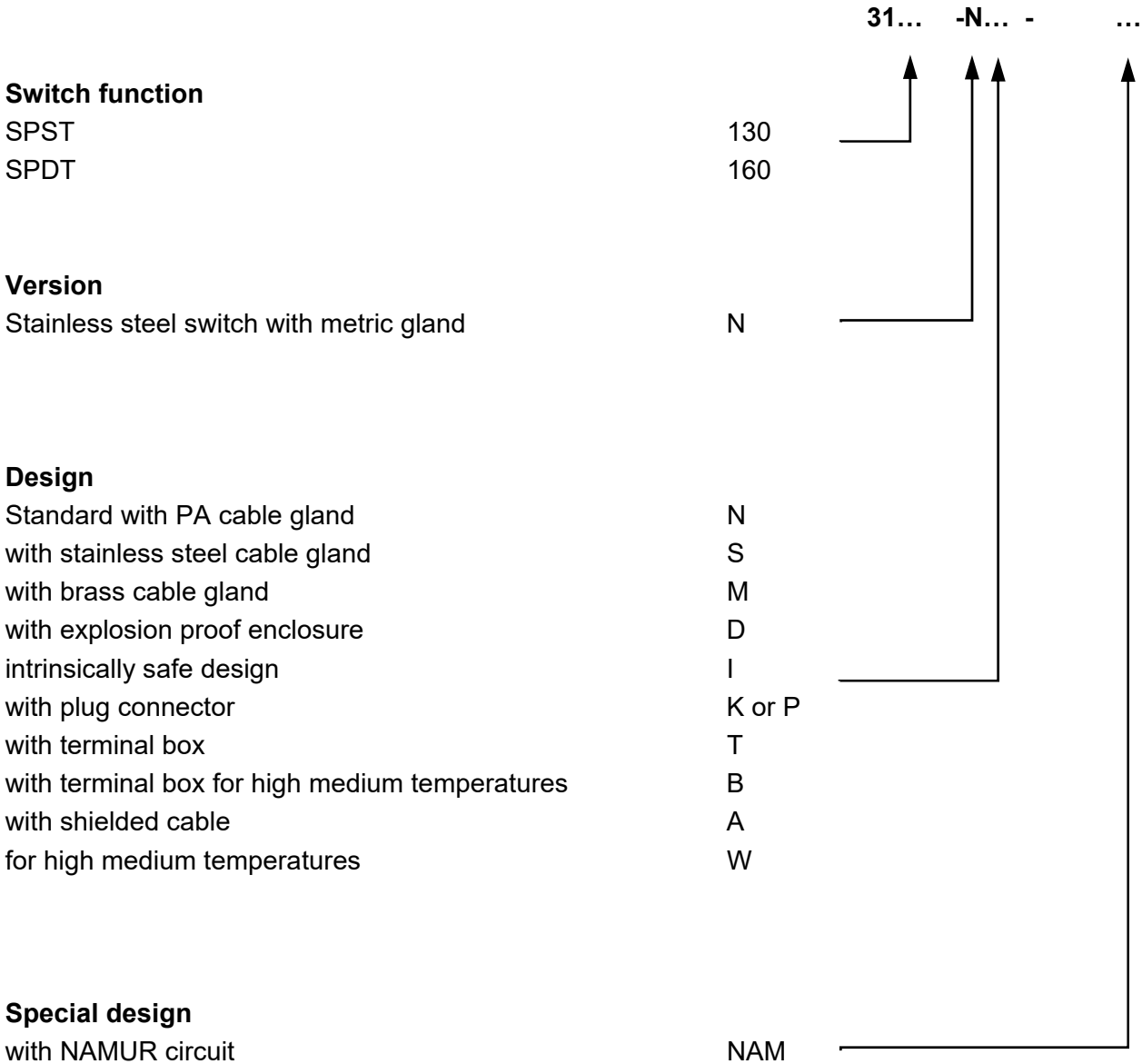

6. Functional description

The magnetic switches are fit laterally as an accessory on the Weka magnetic level indicators and monitor the position of the float by reacting to the magnetic pole contained in the float.

All magnetic switches have a bistable design, i.e. the auxiliary magnet contained in the magnetic switch keeps the switch position until the float magnet changes the switch position by passing by.

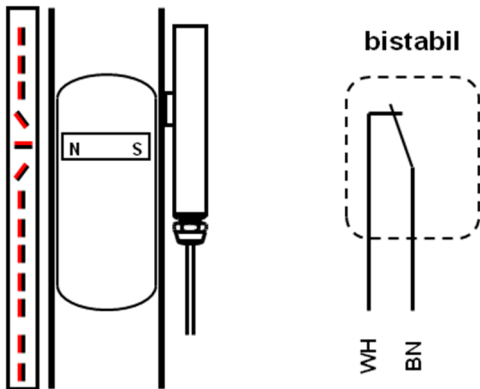

As standard, the magnetic switch is mounted on the outside of the standpipe opposite the indication rail. See adjacent drawing.

The switching logic is reversed if

- the magnetic switch is turned upside down with the cable outlet on the top or
- the switch is mounted in the front next to the indication rail, and if this is technically permitted.

(see assembly instruction)

The float magnet activates the reed switch, as soon as the liquid reaches the switch position.

- Assembly opposite the indication rail
- Bottom of cable outlet



- The magnetic switches of type 311x0-NI (Ex i) are to be operated with appropriate intrinsically safe equipment. The inner capacities are negligible. Please find detailed information in the EU type-examination certificates.



- For each type, none of the specified values must be exceeded. The values apply to ohmic loads. If the magnetic switch is overloaded, this leads to the reed switch being welded and thus the device is defective. Protective circuitry can significantly increase the life expectancy of the magnetic switch.

7. Switch function

SPST = On/off switch
Single Pole - Single Trace



SPDT = Change-over switch
Single Pole - Double Trace

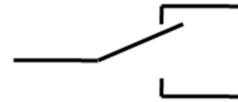

Connection diagram:

	Type	NC (normally closed)	C (common)	NO (normally open)
	37557	WH	BN	
	37589	terminal 1	terminal 2	
	31130-NN	WH	BN	
	31130-NW	BU	BN	
	31130-NA	WH	BN	
	31130-NK	terminal 1	terminal 2	
	31130-NP	terminal 4	terminal 1	
	31130-NT	WH	BN	
	31130-NB	WH	BN	
	31130-NI	WH	BN	
	31130-ND	BN	BU	
	31130-NM	WH	BN	
	31130-NS	WH	BN	
		31160-NN	WH	BN
31160-NW		WH	BN	GN
31160-NA		WH	BN	GN
31160-NK		terminal 3	terminal 1	terminal 2
31160-NP		terminal 2	terminal 1	terminal 4
31160-NT		WH	BN	GN
31160-NB		WH	BN	GN
31160-NI		WH	BN	GN
31160-ND		GY	BK	BN
31160-NM		WH	BN	GN
31160-NS		WH	BN	GN
		31130-NA-NAM	WH	BN
	31130-NW-NAM	BU	BN	

Protection circuitry:

<p>Figure 1 (D.C.)</p> <p>Reed-Switch Inductive load</p> <p>Diode 1N4004</p>	<p>For DC loads:</p> <p>Parallel to inductive load, a diode short-circuits the reversing voltage peak. Thus, the switch is protected against excess load.</p>
<p>Figure 2 (A.C.)</p> <p>Reed-Switch Inductive load</p> <p>100Ω, 1/4W 0,1µF, 600V</p>	<p>For AC loads:</p> <p>A serial combination of resistance and capacitor is assembled parallel to the reed switch. This combination has a high resistance in normal use. In the case of voltage peaks, the resistance is reduced and the excess load is diverted. Thus, the switch is protected.</p>

8. Scope of delivery

- When ordering a level indicator with magnetic switches, hose clamps are included.
- When ordering magnetic switches as spare parts, hose clamps are never included and must be ordered separately. Should you place an order, the hose clamp sizes must be specified:

For pipe diameter	30...40mm	Article number 89249
For pipe diameter	40...57mm and 57...80mm	Article number 89250

9. Unpacking

1. Open the packaging and remove the magnetic switch.
2. Make sure that no further parts remain in the packaging.
3. Visually check the magnetic switch and all parts delivered for potential transport damages. Do not use any damaged or hazardous parts.

10. Disposing of packaging materials

Preserve the environment and properly dispose of or recycle the packaging material.

11. Assembly

Prior to assembly, the preparations for unpacking the magnetic switch must be completed.

Prepare the tools (screwdriver size 4 or nut driver SW 7 – older clamp versions SW 6) and materials (hose clamps) required for the assembly of the magnetic switch.

Position the magnetic switch on the magnetic level indicator in the subsequent specified assembly position and at the level on which you want the switch function. It may be that you have to loosen the closely located hose clamps of the indicator rail in order to introduce the hose clamp of the magnetic switch. After the assembly, all hose clamps must again be tightened.

Check the position and the seat of the magnetic switch after you have finished the work.



- **Assembly position:**
The magnetic switch is to be assembled 180° opposite the indication rail with the cable outlet towards the bottom, taking into account the tolerances. The tolerances depend on the respective pipe diameter (see subsequent drawing).
- **Optional:**
With the exception of Smartline, there is an option to assemble the magnetic switch directly next to the indication rail.



- The cable is to be laid in fixed position.
- The hose clamps should be tightened with a torque of 3 ... 5 Nm
- After the assembly, the switch must be fixed tightly and in line with the float chamber.



- With regard to use in explosion-prone environments created by dusts, the maximum medium temperature is to be observed instead of the ambient temperature.



- Potential equalisation is only guaranteed if both hose clamps are assembled on the standing pipe. If there is no continuous connection between the standing pipe and the potential equalisation or if only a hose clamp can be used due to constructive reasons, a connection to the terminal designed for this purpose must be ensured.

34000

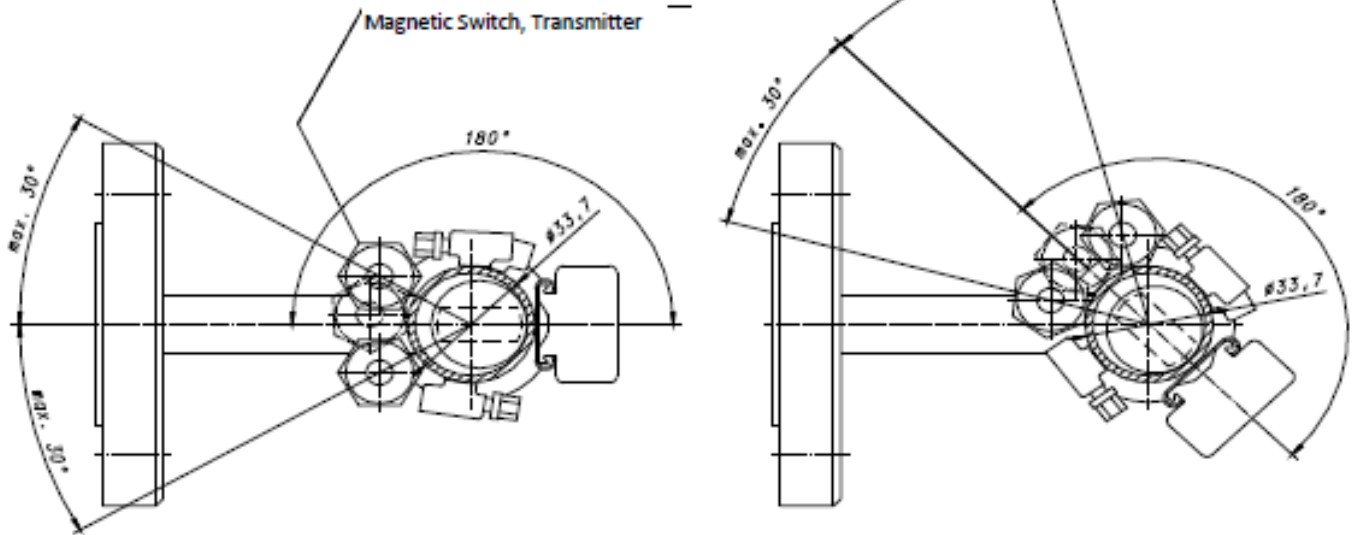

23614, 34300, 32755

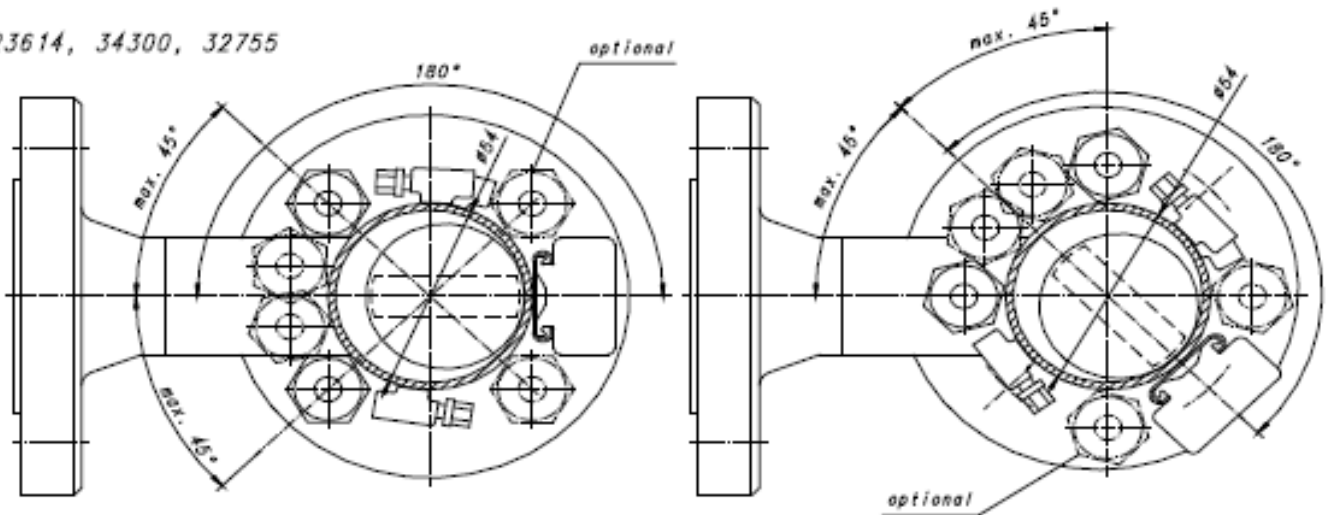

34110

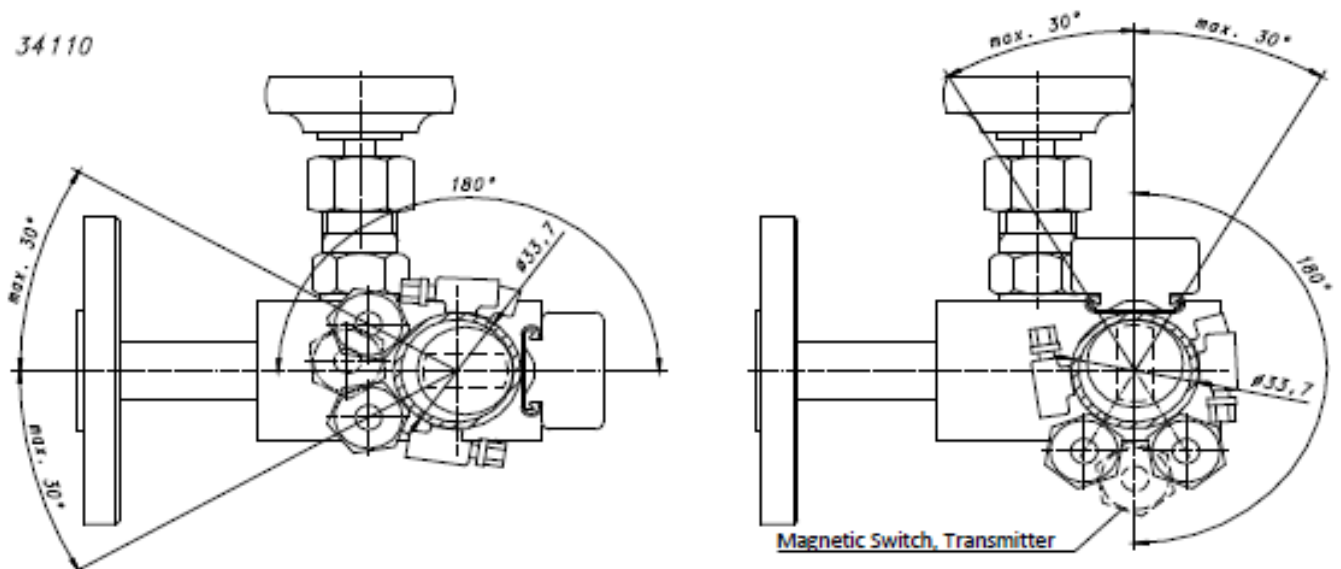

12. Commissioning

Prior to commissioning, the entire assembly (11) must be completed.



- Should the data recorded on the type label (switching capacity, maximum operating temperature, switch function etc.) not match the application, the magnetic switch can be damaged and represent danger to human life and the environment. Make sure that the data recorded on the type plate is a match with the application.



- Inappropriate mounting components (magnetic etc.) can cause error functions and damage and can endanger human life and the environment. Only use components suitable for the application.



- Prior to the first commissioning, the switch position is undefined. Observe the following procedure to establish a defined switching state.



- Prior to use, check the magnetic switch for visible exterior damages. Do not commission a damaged magnetic switch.



- The magnetic switch may only be used for intended purposes recorded on the type plate and in the labelling according to guideline 2014/34/EU and/or IECEx scheme.

The magnetic level indicator is filled with liquid via the tank. As soon as the float floats, it needs some time to adjust itself with regard to the magnetic band of the indication rail. From that point on, the float should indicate the level by turning down the indication leaves.

In order to bring the magnetic switches into a defined switching state, we recommend once driving off the complete tank volume under supervision and visually checking the level so as to be able to guarantee perfect functioning.

It is also possible to bring the switches into the specified position by means of a weak hand magnet (e.g. magnet board). In this way, you can also manually test the mobility of the indication leaves. However, the leaves should always be put back into starting position.

13. Maintenance

In general, the magnetic level indicator is maintenance-free. You should only check the magnetic switch in cases of suspected error function. You find notes on the approach in chapter “Commissioning” (12).



- Should you suspect or detect an error function, it must be immediately rectified. Damaged or faulty components must be replaced with original spare parts.



- When checking the switch function, only use hand magnets which are not too strong and which cannot influence the inner magnet of the switch with regard to its values. Otherwise, this can result in a malfunction of the magnetic switch.



- Clean the magnetic switch only with a damp cloth. Solvents and abrasive cleaners can destroy cables, plastic cable gland and type plate.



- Magnetic switches for the Ex area may only be repaired and modified by the manufacturer (where required in consultation with the named authority).

14. Transport and storage conditions

- Protect magnetic switches against strong thrusts.
- Do not place any heavy items on the magnetic switch and its packaging.
- Store the magnetic switch in a dry environment.
- Avoid contact with water and humidity.
- Protect magnetic switch against strong magnetic fields.
- Temperature: -10°C ... +50°C
- Relative humidity: 10% ... 95%

15. Technical data

Dimensions:	see data sheet	
Minimum medium temperature:	all types	-50°C
Maximum medium temperature:	311x0-NW	+350°C
	31130-NW-NAM	+250°C
	all other types	+150°C
Minimum ambient temperature:	all types	-20°C
Maximum ambient temperature:	all types	+80°C
Standard cable lengths:	xxxxx/3	3 m
	xxxxx/5	5 m
	xxxxx/10	10 m
	xxxxx/20	20 m
Hysteresis:	37557, 37589	3 mm
	all other types	10 mm

Switching capacities:

Type	maximum voltage [V]	maximum current [A]	maximum AC output [VA]	maximum DC output [W]
37557, 37589	100	0.5	10	10
all 31130 (SPST)	250	1.3	80	80
all 31160 (SPDT)	230	1.0	60	60
all -NAM	10.6	0.06	-	0.2

Protection class:

Type	Protection class according to EN 60529
37557 31130-NN, -NW, -NA, -NM, -NS, -NP 31160-NN, -NW, -NA, -NM, -NS, -NP 31130-NA-NAM 31130-NW-NAM	IP68 - 5bar
31130-NI, -ND 31160-NI, -ND	IP68 - 10bar
37589 (when plugged) 31130-NT, -NB 31160-NT, -NB	IP65
31130-NK (when plugged) 31160-NK (when plugged)	IP67

Housing material:	Stainless steel, 316L
Cable gland material:	see data sheet
Cable material:	see data sheet

16. Dismantling / Disposal

- **Dismantling**

Prior to dismantling, make sure that the magnetic switch has been disconnected from the mains and that the missing switch function does not have any effect on the subsequent processes.



- **Disposal**

Preserve the environment and properly dispose of the magnetic switch.

17. Troubleshooting

Problem	Possible causes	Possible solution
1. No visual level display despite liquid being in the tank.	<p>Float is blocked due to dirt in the float chamber.</p> <p>Float is damaged, filled with liquid and has sunk.</p> <p>Float is stuck on magnetic or magnetisable components assembled outside the float chamber.</p>	<p>Clean float chamber and float (see instruction manual of the magnetic level indicator)</p> <p>Replace the float. Compare test pressure of the system with the type plate information.</p> <p>Look for iron parts along the magnetic level indicator by means of magnet (clamps, screws etc.), remove them and respectively replace them with original add-on components.</p>
2. No switch function	<p>The attachment does not correspond to the assembly instructions.</p> <p>The magnetic switch is not activated by the float.</p>	<p>Check correctly assembled. Consider that accessories have to be moved/turned when “moving/turning” the indication rail. Without indicator float, the float has no guidance and thus cannot activate the accessories!</p> <p>Check the function of the magnetic level indicator according to point 1. Ensure that the right combination of float chamber type and float was selected.</p>
3. Magnetic switch does not react bistable (monostabile)	It could be that the auxiliary magnet in the magnetic switch has been demagnetised or moved.	Check the float selection with a second magnet. Where required, replace the faulty magnetic switch.
4. Switch contacts are permanently open/closed.	The magnetic switch was probably overloaded.	Check the applied voltages and currents and make sure that their values are below the maximum values indicated on the type plate. Where required, check the protective circuitry. When the switch is opened, this changes the internal position of the reed switch and causes error functions!

18. Labelling



- The magnetic switch may only be used for the intended use recorded on the type plate. Please observe the information on the type plate.



19. Customer service

You find a list with all WEKA representatives worldwide under <https://www.weka-ag.ch/> >representatives and your choice of country

or contact us directly under

Weka AG

Schuerlistrasse 8
CH-8344 Baeretswil
Switzerland

Phone +41 43 833 43 43
Email level@weka-ag.ch

20. EU- Baumusterprüfbescheinigungen



Prüf- und Zertifizierungsstelle

ZELM Ex



(1) EC-TYPE-EXAMINATION CERTIFICATE

(2) Equipment and Protective Systems Intended for Use in Potentially Explosive Atmospheres - **Directive 94/9/EC**

(3) EC-TYPE-EXAMINATION CERTIFICATE Number:

ZELM 03 ATEX 0156

(4) Equipment: **Magnetic switch Type 31130-NI/* either Type 31160-NI/***

(5) Manufacturer: **WEKA AG**

(6) Address: **CH 8344 Bäretswil**

(7) This equipment and any acceptable variation thereto are specified in the schedule to this certificate and the documents therein referred to.

(8) The Prüf- und Zertifizierungsstelle ZELM Ex, notified body No. 0820 in accordance with Article 9 of the Council Directive 94/9/EC of 23 March 1994, certifies that this equipment has been found to comply with the Essential Health and Safety Requirements relating to the design and construction of equipment and protective systems intended for use in potentially explosive atmospheres, given in Annex II to the Directive.

The examination and test results are recorded in the confidential report ZELM Ex 0510315204.

(9) Compliance with the Essential Health and Safety Requirements has been assured by compliance with:

EN 50014:1997 +A1 +A2

EN 50020 :1994

EN 50281-1-1: 1998

(10) If the sign "X" is placed after the certificate number, it indicates that the equipment is subject to special conditions for safe use specified in the schedule to this certificate.

(11) This EC-type-examination Certificate relates only to the design, examination and tests of the specified equipment or protective system in accordance to the Directive 94/9/EC. Further requirements of the Directive apply to the manufacturing process and supply of this equipment or protective system. These are not covered by this Certificate.

(12) The marking of the equipment shall include the following:



II 2 GD T 85°C EEx ia IIC T6

Zertifizierungsstelle ZELM Ex



Braunschweig, July 16, 2003

Dipl.-Ing. Harald Zelm

Sheet 1/2

EC-type-examination Certificates without signature and stamp are not valid. The certificates may only be circulated without alteration. Extracts or alterations are subject to approval by the Prüf- und Zertifizierungsstelle ZELM Ex. This English version is based on the German text. In the case of dispute, the German text shall prevail.

Prüf- und Zertifizierungsstelle ZELM Ex • Siekgraben 56 • D-38124 Braunschweig

**Prüf- und Zertifizierungsstelle****ZELM Ex**

(13)

SCHEDULE

(14)

EC-TYPE-EXAMINATION CERTIFICATE ZELM 03 ATEX 0156(15) Description of equipment

The magnetic switches serves to the signal generation at level change of media.

The star (*) in the type designation indicates the length of the firmly connected line in "meter".

The permissible ambient temperature range conducts -20 °C to + 80 °C.

Electrical data

Switching current circuit

type of protection Intrinsic Safety EEx ia IIC

for connection to certified intrinsically safe circuits with the following maximum values:

$$\begin{aligned} U_i &= 250 \text{ V} \\ I_i &= 1 \text{ A} \end{aligned}$$

The effective internal capacitance and the effective internal inductance are negligibly small.

References:

The instruction manual has to be considered.

Additionally the maximum effective capacitance and the maximum effective inductance of the firmly connected line have to be considered according to length due to the information in the operation manual.

(16) Report No.

ZELM Ex 0510315204

(17) Special conditions for safe use

not applicable

(18) Essential Health and Safety Requirements

met by standards

Zertifizierungsstelle **ZELM Ex**

Braunschweig, July 16, 2003

H. Zelm
Dipl.-Ing. Harald Zelm

Sheet 2/2

EC-type-examination Certificates without signature and stamp are not valid. The certificates may only be circulated without alteration. Extracts or alterations are subject to approval by the Prüf- und Zertifizierungsstelle ZELM Ex. This English version is based on the German text. In the case of dispute, the German text shall prevail.

Prüf- und Zertifizierungsstelle ZELM Ex • Siekgraben 56 • D-38124 Braunschweig

1. Supplement

(Supplement according to EC-Directive 94/9 Annex III letter 6)

ZELM ex

to EC-type examination Certificate

ZELM 03 ATEX 0156

Equipment: **Magnetic switch type 31130-NI* and type 31160-NI***
 Manufacturer: **Weka AG**
 Address: **CH-8344 Bäretswil**

Description of supplement

Within the scope of this 1. supplement the compliance of the equipment to the current Standards was checked and the marking has been adapted correspondingly. Furthermore the Electrical Data and the permissible ambient temperature range were changed.

The marking is in future:

 **II 2 G Ex ia IIC T6 Gb**
II 2 D Ex iaD IIIC T85°C Db

The permissible ambient temperature range is in future -20°C to $+65^{\circ}\text{C}$.

Electrical Data

The Electrical Data is in future:

Switching current circuit:

in type of protection Intrinsic Safety Ex ia IIC resp. Ex iaD IIIC
 Only for the connection to certified intrinsically safe circuits
 with the following maximum values:

for type 31130-NI*

$$U_i = 250 \text{ V}$$

$$I_i = 1,3 \text{ A}$$

for type 31160-NI*

$$U_i = 230 \text{ V}$$

$$I_i = 1,0 \text{ A}$$

The effective internal capacitance and internal inductance of the switches are negligibly small. However the permanently connected cable has to be considered additionally having $C = 110 \text{ pF/m}$ and $L = 0,7 \text{ }\mu\text{H/m}$.

Reference

The instruction manual has to be considered.

At media temperatures of above 85°C the temperature class has to be adapted correspondingly to the instruction manual.

**1. Supplement
to EC-type examination Certificate ZELM 03 ATEX 0156**

ZELM ex

All other data of the EC-type-examination Certificate ZELM 03 ATEX 0156 remain unchanged and are valid further on.

The magnetic switches type 31130-NI/* and type 31160-NI/* may only be manufactured in future under consideration of this 1. Supplement.

Report No.

ZELM Ex 1081019816

Essential Health and Safety Requirements

The essential Health and Safety Requirements are fulfilled by compliance with the following Standards:

EN 60079-0:2009

EN 60079-11:2007

EN 61241-11:2006

Braunschweig, December 14th, 2010

ZELM ex

**Zertifizierungs-
stelle**

Zertifizierungsstelle ZELM ex
Dipl.-Ing. Harald Zelm



Page 2 of 2

EC-Type-Examination Certificate without Signature and Stamp are not valid.
The Certificate may only be circulated without alteration. Extracts or alterations are subject of approval by the Prüf- und Zertifizierungsstelle ZELM ex. This English version is based on the German text. In the case of dispute, the German text shall prevail.

ZELM ex
Prüf- und Zertifizierungsstelle
Siekgraben 56 · D-38124 Braunschweig

**Prüf- und Zertifizierungsstelle****ZELM Ex****(1) EC-TYPE-EXAMINATION CERTIFICATE**

(2) Equipment and Protective Systems Intended for Use in Potentially Explosive Atmospheres - **Directive 94/9/EC**

(3) EC-TYPE-EXAMINATION CERTIFICATE Number:

ZELM 03 ATEX 0190

(4) Equipment: **Magnetic switch Type 31130-ND/* either Type 31160-ND/***

(5) Manufacturer: **WEKA AG**

(6) Address: **CH 8344 Bäretswil**

(7) This equipment and any acceptable variation thereto are specified in the schedule to this certificate and the documents therein referred to.

(8) The Prüf- und Zertifizierungsstelle ZELM Ex, notified body No. 0820 in accordance with Article 9 of the Council Directive 94/9/EC of 23 March 1994, certifies that this equipment has been found to comply with the Essential Health and Safety Requirements relating to the design and construction of equipment and protective systems intended for use in potentially explosive atmospheres, given in Annex II to the Directive.

The examination and test results are recorded in the confidential report ZELM Ex 1060319253.

(9) Compliance with the Essential Health and Safety Requirements has been assured by compliance with:

EN 50014:1997 +A1 +A2**EN 50018 :2000****EN 50281-1-1: 1998**

(10) If the sign "X" is placed after the certificate number, it indicates that the equipment is subject to special conditions for safe use specified in the schedule to this certificate.

(11) This EC-type-examination Certificate relates only to the design, examination and tests of the specified equipment or protective system in accordance to the Directive 94/9/EC. Further requirements of the Directive apply to the manufacturing process and supply of this equipment or protective system. These are not covered by this Certificate.

(12) The marking of the equipment shall include the following:

**II 2 GD T 85°C EEx d IIC T6**Zertifizierungsstelle **ZELM Ex**
Dipl.-Ing. Harald Zelm

Braunschweig, January 26, 2004

Sheet 1/2

EC-type-examination Certificates without signature and stamp are not valid. The certificates may only be circulated without alteration. Extracts or alterations are subject to approval by the Prüf- und Zertifizierungsstelle ZELM Ex. This English version is based on the German text. In the case of dispute, the German text shall prevail.

Prüf- und Zertifizierungsstelle ZELM Ex • Siekgraben 56 • D-38124 Braunschweig

**Prüf- und Zertifizierungsstelle****ZELM Ex****SCHEDULE**

(13)

(14) **EC-TYPE-EXAMINATION CERTIFICATE ZELM 03 ATEX 0190**(15) Description of equipment

The magnetic switches serves to the signal generation at level change of media.

The star (*) in the type designation indicates the length of the firmly connected line in "meter".

The permissible ambient temperature range conducts -20 °C to + 80 °C.

Electrical data

Switching current circuit	rated values	31130 ND/*	31160 ND/*
		U = 250 V	U = 230 V
		I = 1,3 A	I = 1 A
		S = 80 VA	S = 60VA
		P = 80 W	P = 60 W

References:

The instruction manual has to be considered.

For media temperatures higher than 85°C, the temperature class has to be assimilated according to the data in the instruction manual.

(16) Report No.

ZELM Ex 1060319253

(17) Special conditions for safe use

not applicable

(18) Essential Health and Safety Requirements

met by standards

Zertifizierungsstelle **ZELM Ex**

Dipl.-Ing. Harald Zelm



Braunschweig, January 26, 2004

Sheet 2/2

EC-type-examination Certificates without signature and stamp are not valid. The certificates may only be circulated without alteration. Extracts or alterations are subject to approval by the Prüf- und Zertifizierungsstelle ZELM Ex. This English version is based on the German text. In the case of dispute, the German text shall prevail.

Prüf- und Zertifizierungsstelle ZELM Ex • Siekgraben 56 • D-38124 Braunschweig

1. Supplement

(Supplement according to EC-Directive 94/9 Annex III letter 6)

ZELM ex

to EC-type-examination Certificate

ZELM 03 ATEX 0190

Equipment: **Magnetic switch type 31130-ND/* and type 31160-ND/***
Manufacturer: **WEKA AG**
Address: **Schürlistraße 8, CH-8344 Bäretswil**

Description of supplement

The integral cable gland, which is examined with a separate EC-type examination Certificate, is modified by the cable gland manufacturer. This Supplement concerns the consideration of this modification. Moreover another permanent connected cable is used in future. Furthermore the compliance of the equipment to the current Standards was checked and the marking has been adapted correspondingly.

The marking is in future:

 **II 2 G Ex d IIC T6 Gb**
II 2 D Ex tb IIIC T85°C Db

The permissible ambient temperature range, the electrical and all other technical data as well as the references according to the EC-type-examination Certificate ZELM 03 ATEX 0190 remain unchanged and are also valid for this 1. Supplement.

The magnetic switch type 31130-ND/* and type 31160-ND/* shall be only manufactured in future according to this 1. Supplement.

Report No.

ZELM Ex 14713131019

Essential Health and Safety Requirements

The essential health and safety requirements are still fulfilled by compliance with the following Standards:

EN 60079-0:2009

EN 60079-1:2007

EN 60079-31:2009

ZELM ex**Zertifizierungs-
stelle**

Braunschweig, 2014-02-11

Zertifizierungsstelle ZELM ex
Dipl.-Ing. Harald Zelm



**ZELM
ex**

Sheet 1 of 1

EC-type-examination Certificates without signature and stamp are not valid. This EC-type-examination Certificate may only be circulated without alteration. Extracts or alterations are subject to approval by the Prüf- und Zertifizierungsstelle ZELM ex. This English version is based on the German text. In the case of dispute, the German text shall prevail.

ZELM ex
Prüf- und Zertifizierungsstelle
Siekgraben 56 · D-38124 Braunschweig

21. IECEx- Certificate of Conformity

		<h1>IECEX Certificate of Conformity</h1>
INTERNATIONAL ELECTROTECHNICAL COMMISSION IEC Certification Scheme for Explosive Atmospheres <small>for rules and details of the IECEx Scheme visit www.iecex.com</small>		
Certificate No.:	<input type="text" value="IECEX ZLM 10.0003"/> issue No.:0	<input type="text" value="Certificate history:"/>
Status:	<input type="text" value="Current"/>	
Date of Issue:	2010-12-15	Page 1 of 3
Applicant:	Weka AG Schuerlistr.8 8344 Baeretswil Switzerland	
Electrical Apparatus: <i>Optional accessory:</i>	magnetic switch type 31130-NV* and type 31160-NV*	
Type of Protection:	Intrinsic Safety	
Marking:	Ex ia IIC T6 Gb Ex iaD IIIC T85°C Db	
Approved for issue on behalf of the IECEx Certification Body:	Dipl.-Ing. Harald Zelm	
Position:	Head of Certification Body	
Signature: <i>(for printed version)</i>	<hr/>	
Date:	<hr/>	
<p>1. This certificate and schedule may only be reproduced in full. 2. This certificate is not transferable and remains the property of the issuing body. 3. The Status and authenticity of this certificate may be verified by visiting the Official IECEx Website.</p>		
Certificate issued by: ZELM Explosionsschutz GmbH Siekgraben 56 D-38124 Braunschweig Germany		



IECEX Certificate of Conformity

Certificate No.: IECEx ZLM 10.0003

Date of Issue: 2010-12-15

Issue No.: 0

Page 2 of 3

Manufacturer: **Weka AG**
Schuerlistr. 8
8344 Baeretswil
Switzerland

Manufacturing location(s):

This certificate is issued as verification that a sample(s), representative of production, was assessed and tested and found to comply with the IEC Standard list below and that the manufacturer's quality system, relating to the Ex products covered by this certificate, was assessed and found to comply with the IECEx Quality system requirements. This certificate is granted subject to the conditions as set out in IECEx Scheme Rules, IECEx 02 and Operational Documents as amended.

STANDARDS:

The electrical apparatus and any acceptable variations to it specified in the schedule of this certificate and the identified documents, was found to comply with the following standards:

IEC 60079-0 : 2007-10 Explosive atmospheres - Part 0: Equipment - General requirements
Edition: 5

IEC 60079-11 : 2006 Explosive atmospheres - Part 11: Equipment protection by intrinsic safety "I"
Edition: 5

IEC 61241-11 : 2005 Electrical apparatus for use in the presence of combustible dusts - Part 11: Protection by intrinsic safety 'ID'
Edition: 1

*This Certificate **does not** indicate compliance with electrical safety and performance requirements other than those expressly included in the Standards listed above.*

TEST & ASSESSMENT REPORTS:

A sample(s) of the equipment listed has successfully met the examination and test requirements as recorded in

Test Report:

DE/ZLM/ExTR10.0003/00

Quality Assessment Report:

DE/ZLM/QAR09.0001/00



IECEx Certificate of Conformity

Certificate No.: IECEx ZLM 10.0003

Date of Issue: 2010-12-15

Issue No.: 0

Page 3 of 3

Schedule

EQUIPMENT:

Equipment and systems covered by this certificate are as follows:

The magnetic switches type 31130-NI* and type 31160-NI* are for the generation of a signal at a level change of media.

Therefore the switch will be used together with a visual level indicator.

The type 31130-NI* uses an on/off switch, the type 31160-NI* uses a changeover switch.

The star (*) indicates the length in meter of the permanently connected cable.

CONDITIONS OF CERTIFICATION: NO



IECEX Certificate of Conformity

INTERNATIONAL ELECTROTECHNICAL COMMISSION IEC Certification Scheme for Explosive Atmospheres

for rules and details of the IECEx Scheme visit www.iecex.com

Certificate No.:	IECEX ZLM 14.0002	Issue No: 0	<u>Certificate history:</u> Issue No. 0 (2014-02-11)
Status:	Current	Page 1 of 4	
Date of Issue:	2014-02-11		
Applicant:	WEKA AG Schuerlistrasse 8 8344 Baeretswil Switzerland		
Electrical Apparatus: Optional accessory:	Magnetic switch type 31130-ND/* and type 31160-ND/*		
Type of Protection:	Flameproof enclosure, dust ignition protection by enclosure		
Marking:	Ex d IIC T8 Gb Ex tb IIIC T85°C Db		

Approved for issue on behalf of the IECEx
Certification Body:

Dipl.-Ing. Harald Zelm

Position:

Head of Certification Body

Signature:
(for printed version)

Date:

1. This certificate and schedule may only be reproduced in full.
2. This certificate is not transferable and remains the property of the issuing body.
3. The Status and authenticity of this certificate may be verified by visiting the [Official IECEx Website](http://www.iecex.com).

Certificate issued by:

ZELM Explosionsschutz GmbH
Siekgraben 56
D-38124 Braunschweig
Germany





IECEX Certificate of Conformity

Certificate No: IECEX ZLM 14.0002 Issue No: 0
Date of Issue: 2014-02-11 Page 2 of 4
Manufacturer: WEKA AG
Schuerlistrasse 8
8344 Baeretswil
Switzerland

Additional Manufacturing
location(s):

This certificate is issued as verification that a sample(s), representative of production, was assessed and tested and found to comply with the IEC Standard list below and that the manufacturer's quality system, relating to the Ex products covered by this certificate, was assessed and found to comply with the IECEX Quality system requirements. This certificate is granted subject to the conditions as set out in IECEX Scheme Rules, IECEX 02 and Operational Documents as amended.

STANDARDS:

The electrical apparatus and any acceptable variations to it specified in the schedule of this certificate and the identified documents, was found to comply with the following standards:

IEC 60079-0 : 2007-10 Edition:5	Explosive atmospheres - Part 0:Equipment - General requirements
IEC 60079-1 : 2007-04 Edition:6	Explosive atmospheres - Part 1: Equipment protection by flameproof enclosures "d"
IEC 60079-31 : 2008 Edition:1	Explosive atmospheres – Part 31: Equipment dust ignition protection by enclosure 't'

This Certificate does not indicate compliance with electrical safety and performance requirements other than those expressly included in the Standards listed above.

TEST & ASSESSMENT REPORTS:

A sample(s) of the equipment listed has successfully met the examination and test requirements as recorded in

Test Report:

[DE/ZLM/ExTR 14.0002/00](#)

Quality Assessment Report:

[DE/ZLM/QAR09.0001/01](#)



IECEX Certificate of Conformity

Certificate No: IECEX ZLM 14.0002

Issue No: 0

Date of Issue: 2014-02-11

Page 3 of 4

Schedule

EQUIPMENT:

Equipment and systems covered by this certificate are as follows:

The magnetic switches type 31130-ND/* and type 31160-ND/* are for the generation of a signal at a level change of media. Therefore the switch will be used together with a visual level indicator.

The magnetic switches are intended for use in hazardous areas. The type 31130-ND/* uses an on/off switch, the type 31160-ND/* uses a changeover switch. The star (*) indicates the length in meter of the permanently connected cable.

Permissible ambient temperature range: -20°C...+80°C

Electrical data:

Switching capacity: rated values:

Type 31130-ND/*: U = 250 V, I = 1.3 A, S = 80 VA, P = 80 W

Type 31160-ND/*: U = 230 V, I = 1.0 A, S = 60 VA, P = 60 W

CONDITIONS OF CERTIFICATION: NO



IECEX Certificate of Conformity

Certificate No: IECEX ZLM 14.0002

Issue No: 0

Date of Issue: 2014-02-11

Page 4 of 4

EQUIPMENT (continued):

References:

The instruction manual has to be observed.

At medium temperatures of above 85°C the temperature class has to be adapted correspondingly to the instruction manual.

22. Declaration of Conformity

EU - KONFORMITÄTSERKLÄRUNG EU - DECLARATION OF CONFORMITY

Wir
We

WEKA AG

(Name des Herstellers) (Manufacturers name)

erklären in alleiniger Verantwortung, dass das Produkt
declare under our sole responsibility that the product

Magnetschalter / Magnetic Switch

Typen: 37557; 37589; 20000714; 31130-NN; 31160-NN; 31130-NW; 31160-NW; 31130-NA;
31160-NA; 31130-NK; 31160-NK; 31130-NP; 31160-NP; 31130-NT; 31160-NT;
31130-NB; 31160-NB; 31130-NM; 31160-NM; 31130-NS; 31160-NS; 31130-NA-NAM;
31130-NW-NAM

(Diese Produkte dürfen NICHT für Ex- Anwendungen eingesetzt werden /
These products should NOT be used for Ex applications)

(Bezeichnung Typ oder Modell, Los-, Chargen- oder Seriennummer, möglichst Herkunft und Stückzahl)
(Name, type or model, lot, batch or serial number, possibly sources and numbers of items)

auf das sich diese Erklärung bezieht, mit den folgenden Normen oder normativen Dokumenten übereinstimmt
to which this declaration relates is in conformity with the following standards or other normative documents

EN 61326-1:2011
EN 61010-1:2011

(Titel und/oder Nummer sowie Ausgabedatum der Normen oder der anderen normativen Dokumente)
(Title and/or number and date of issue of the standards or other normative documents)

Gemäss den Bestimmungen der Richtlinie(n),
Following the provisions of Directive(s),
(falls zutreffend) (if applicable)

2014/30/EU (EMV); 2014/35/EU (LVD)

(Ort und Datum der Ausstellung)
(Place and date of issue)

(Name und Unterschrift des Befugten)
(Name and signature of authorized person)

Bäretswil, den 25.07.2016



Robert Schäppi
(Quality Manager)



Stefan Otto
(Produkt Manager)

EU - KONFORMITÄTSERKLÄRUNG EU - DECLARATION OF CONFORMITY

Wir
We

WEKA AG

(Name des Herstellers) (Manufacturers name)

erklären in alleiniger Verantwortung, dass das Produkt
declare under our sole responsibility that the product

Magnetschalter / Magnetic Switch

Typen: 31130-NI, 31160-NI

(Bezeichnung Typ oder Modell, Los-, Chargen- oder Seriennummer, möglichst Herkunft und Stückzahl)
(Name, type or model, lot, batch or serial number, possibly sources and numbers of items)

auf das sich diese Erklärung bezieht, mit den folgenden Normen oder normativen Dokumenten übereinstimmt
to which this declaration relates is in conformity with the following standards or other normative documents

EN 61326-1:2011
EN 60079-0:2009
EN 60079-11:2007
EN 60241-11:2006

EG- Baumusterprüfbescheinigung / EC Type Examination Certificate ZELM 03 ATEX 0156

(Titel und/oder Nummer sowie Ausgabedatum der Normen oder der anderen normativen Dokumente)
(Title and/or number and date of issue of the standards or other normative documents)

Gemäss den Bestimmungen der Richtlinie(n),
Following the provisions of Directive(s),
(falls zutreffend) (if applicable)

2014/30/EU (EMV); 2014/34/EU (ATEX)

(Ort und Datum der Ausstellung)
(Place and date of issue)

Bäretswil, den 25.07.2016

(Name und Unterschrift des Befugten)
(Name and signature of authorized person)

Robert Schäppi
(Quality Manager)

Stefan Otto
(Produkt Manager)

EU - KONFORMITÄTSERKLÄRUNG EU - DECLARATION OF CONFORMITY

Wir
We

WEKA AG

(Name des Herstellers) (Manufacturers name)

erklären in alleiniger Verantwortung, dass das Produkt
declare under our sole responsibility that the product

Magnetschalter / Magnetic Switch

Typen: 31130-ND, 31160-ND

(Bezeichnung Typ oder Modell, Los-, Chargen- oder Seriennummer, möglichst Herkunft und Stückzahl)
(Name, type or model, lot, batch or serial number, possibly sources and numbers of items)

auf das sich diese Erklärung bezieht, mit den folgenden Normen oder normativen Dokumenten übereinstimmt
to which this declaration relates is in conformity with the following standards or other normative documents

EN 61326-1:2011
EN 60079-0:2009
EN 60079-1:2007
EN 60079-31:2009

EG- Baumusterprüfbescheinigung / EC Type Examination Certificate ZELM 03 ATEX 0190

(Titel und/oder Nummer sowie Ausgabedatum der Normen oder der anderen normativen Dokumente)
(Title and/or number and date of issue of the standards or other normative documents)

Gemäss den Bestimmungen der Richtlinie(n),
Following the provisions of Directive(s),
(falls zutreffend) (if applicable)

2014/30/EU (EMV); 2014/34/EU (ATEX)

(Ort und Datum der Ausstellung)
(Place and date of issue)

Bäretswil, den 25.07.2016

(Name und Unterschrift des Befugten)
(Name and signature of authorized person)

Robert Schäppi
(Quality Manager)

Stefan Otto
(Produkt Manager)