



Market solution

Drive System for robotic joints



WE CREATE MOTION

FAULHABER drives robotics forward

For decades, we have been a driving force in the development of application-specific drive solutions and have set benchmarks across a wide range of markets. Our ability to anticipate future trends and adapt our production to new requirements makes us the ideal partner when it comes to developing innovative solutions together and bringing them to market quickly.

We develop the perfect drive system for your robot

With an exceptionally short time-to-market, new dimensions, and perfectly matched features for robotics, the FAULHABER BXI is a prime example of the efficiency of this process. With this motor, we are introducing the most powerful integrated drive system in our portfolio to date – a direct response to our customers' needs. Together with them, we develop and manufacture specific drive solutions for a new generation of robotic applications.



Natural mobility for humanoid robots

Human-like movements require maximum precision, strength, and dynamics—from the fingertips to the shoulder joints, from the toes to the hips.





For demanding coordinated movements
Intelligent, compact drive systems keep the evolution of robotics moving forward.



Reliable positioning and gripping for cobots
Industrial and automation applications require robust, precise drive systems with intelligent control.



FAULHABER BXI

The new centerpiece for robotics applications

SYSTEM COMPONENTS

- Motor
- Integrated gearhead
- Absolute encoder
- External controller (MC 5010 S)
- Cabling
- Motion Manager support

OPTIMAL CONTROL

When connected to the FAULHABER MC5010 motion controller, a perfectly coordinated system is created for torque-sensitive, high-precision positioning tasks with simultaneous motor protection and easy commissioning thanks to Motion Manager software.

PLUG & PLAY USABILITY

Two robust, shielded M12 electronic interfaces for motor supply and encoder ensure connection to the controller.

HIGH EFFICIENCY AND SMOOTH OPERATION

The internal rotor design with 21 pole pairs, a slotted stator, and iron-core winding ensures low cogging torque and high torque density.



The FAULHABER BXI was developed specifically for the high demands placed on joints in current and future robotics applications. The drive system consists of a unit comprising a motor, integrated planetary gearhead, and high-resolution encoder. Its strength lies in its compactness: maximum performance in minimum space.

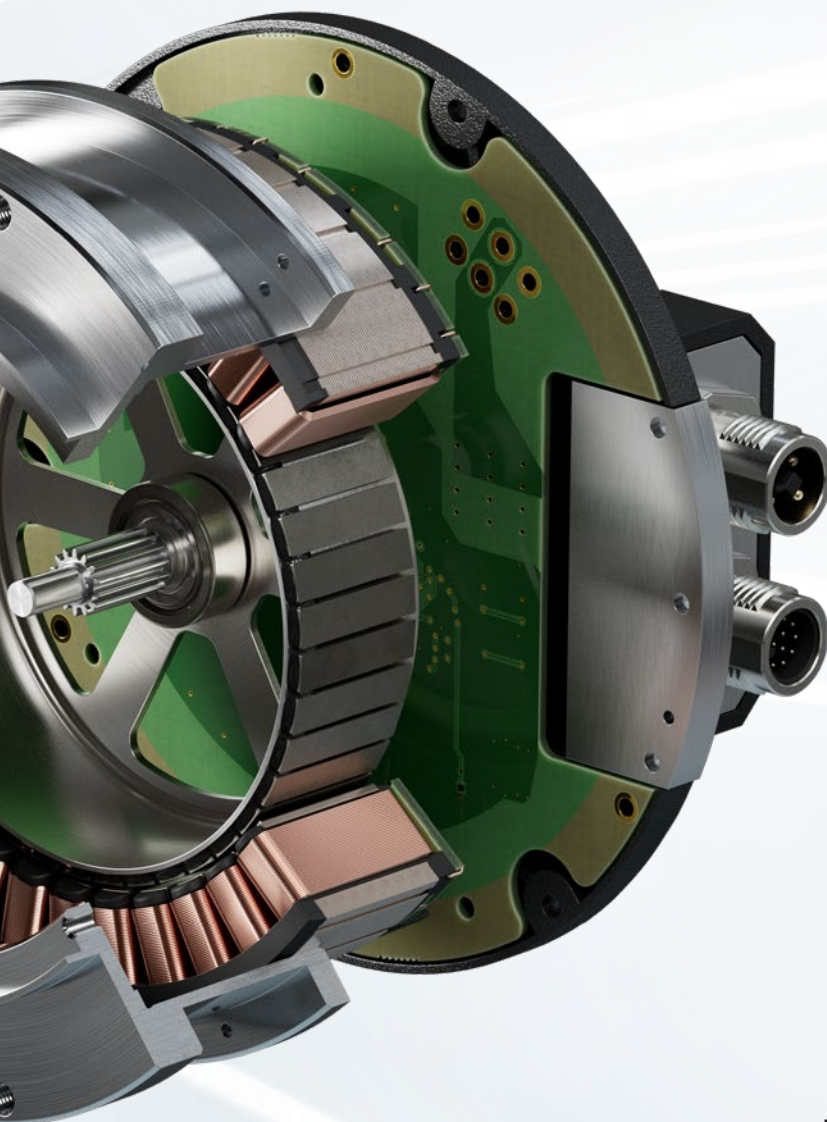

LIGHTWEIGHT, COOL, AND COMPACT

The flat, space-saving aluminum housing guarantees corrosion resistance without coating and ensures optimized cooling. Additional advantages include low weight and high torque density.

SUFFICIENT POWER RESERVES IN THE LIMIT AREA

A low mechanical time constant and low moment of inertia, combined with optimized heat dissipation and iron-core winding, ensure high short-term overload tolerance.

HIGH POWER DENSITY AND LONG SERVICE LIFE

A lightweight, low-backlash planetary gearhead (2 stages in 1) with needle bearings reliably ensures optimal torque transmission.

UNSHAKABLE POSITIONING ACCURACY

The integrated 15-bit SSI absolute encoder, with line driver and compensation algorithm, handles commutation and positioning simultaneously – and is insensitive to interference.

FAULHABER BXI

Facts & Figures

The Series 9317 BXI G internal rotor motor combines robustness and compactness, setting new standards. Its high maximum torque of up to 20 Nm enables effortless dynamic movements for fast response times and precise motion control. With a voltage range up to 50 V, the available interfaces, and a length of only 34 mm, the BXI is easy to integrate. Perfect for applications where every millimeter, every gram, and above all, power counts, e.g., as an articulated joint drive for humanoid robots.

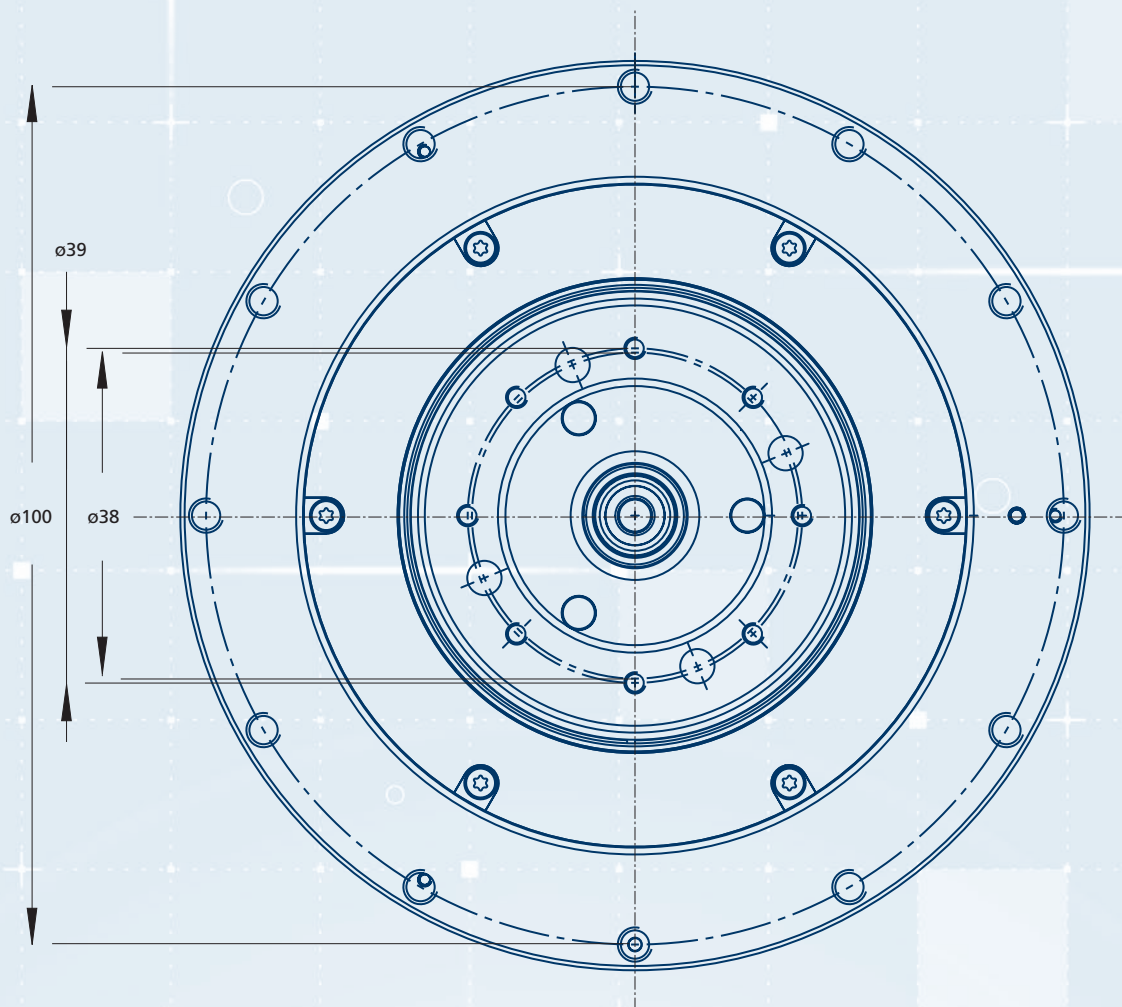
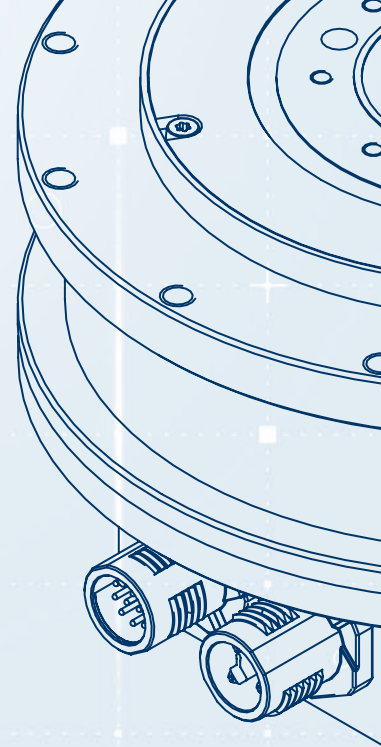

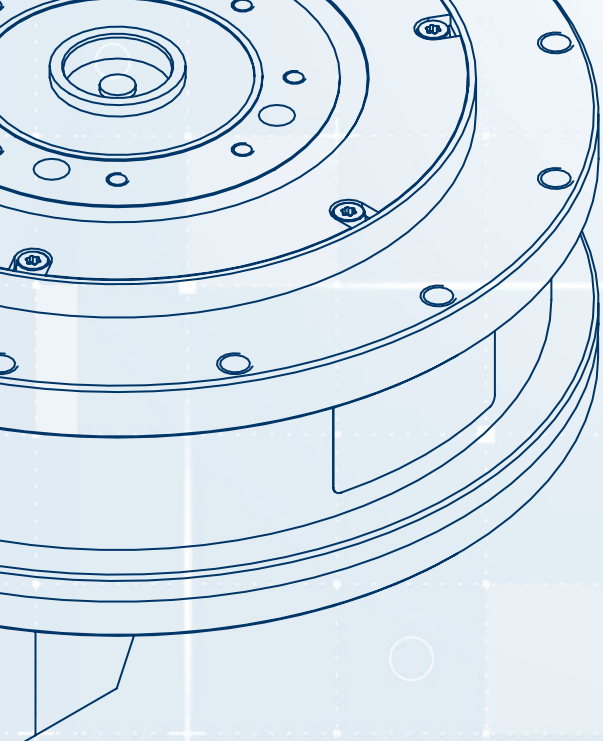

DATA SHEET

9317...BXI G

Mechanical specifications

Mass 987 g
 Reduction ratio 10.5:1

Electrical specifications

Encoder absolute encoder with line driver
 Operating voltage 5 V ±10 %
 Protocol SSI
 Resolution 15 Bit

Voltage range

Motor, DC 0 ... 50 V

Direction of rotation reversible

Operating temperature range

Ambient temperature -25 ... 85°C

Max. temperature

- Motor / housing 100°C
 - Winding, max. permissible 125°C

Max. torque, up to 20 Nm

Max. power output, up to 270 W

Max. phase current, up to 13 A

No-load speed 114 min⁻¹

No-load current phase, rms 0.577 A

No-load voltage, DC 24 V

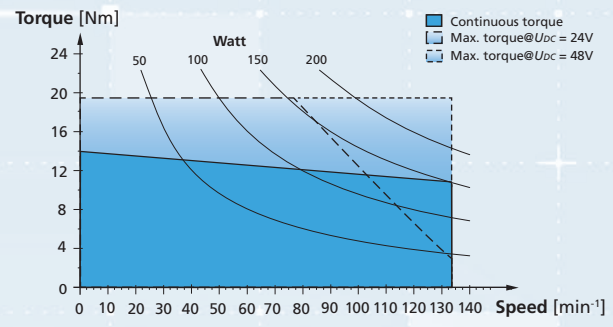
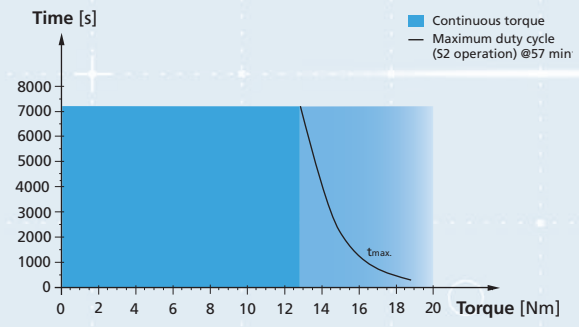
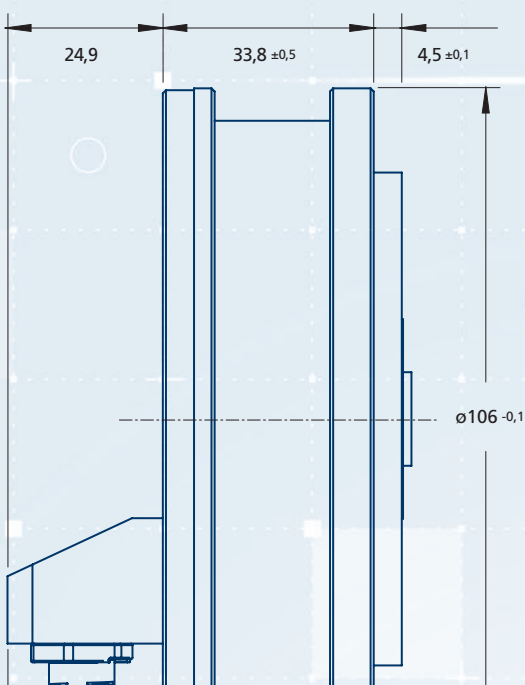
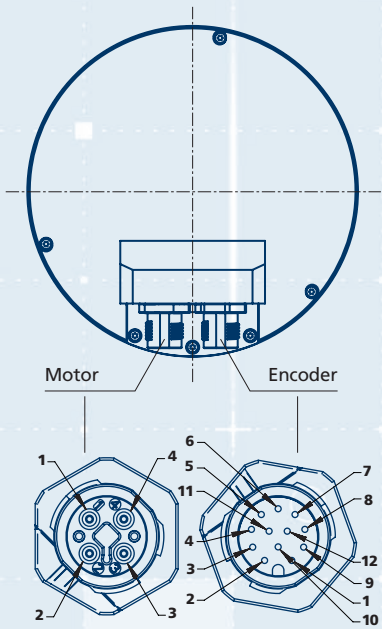

Values valid at 22°C ambient temperature and speed-controlled operation with sinusoidal commutation

More information



[faulhaber.com](https://www.faulhaber.com)



[faulhaber.com/facebook](https://www.faulhaber.com/facebook)



[faulhaber.com/youtube](https://www.faulhaber.com/youtube)



[faulhaber.com/linkedin](https://www.faulhaber.com/linkedin)



[faulhaber.com/instagram](https://www.faulhaber.com/instagram)



Ident-no. 000.9001.02

Contact